



# INSTALLATION INSTRUCTIONS FOR SEMI-LOOSE LAY INSTALLATION

# 01

## CONDITIONS REQUIRED PRIOR TO INSTALLATION

- Do not use different batch numbers in the same room and respect the numerical order of the rolls
- Calculate the amount needed for each room and lay the rolls flat for 24 hours, taking care to leave 1 cm between each roll to allow the product to acclimatise
- It must be installed in the direction of the light or in the direction of the anticipated foot traffic
- Where possible, seams must be positioned outside areas of heavy foot traffic
- The surface must be level, clean, sound, dry, and solid
- For absorbent substrates, a primer must be applied to the adhesive areas
- Subfloor humidity must be  $\leq 2,0$  CM % for cement screed (heated  $\leq 1,8$  CM %) and  $\leq 0,5$  CM % for Calciumsulfat screed (heated  $\leq 0,3$  CM %)

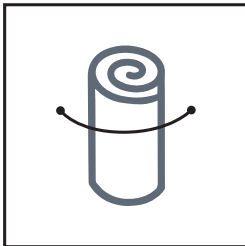

Rolls  $\leq 2$  m  
Stored upright and  
fastened

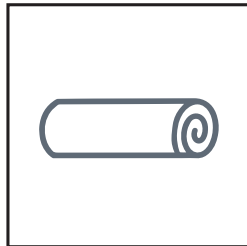

Rolls  $\geq 2$  m  
Stored horizontally,  
not stacked

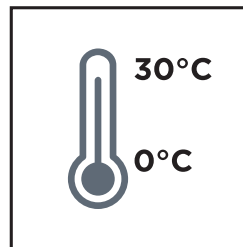

Ambient and substrate  
temperature between  
15° and 30°

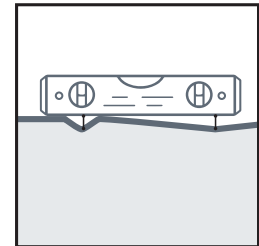

Substrate flatness  
< 4 mm under the 2 m  
rule

### Product information

- Beauflor CV floorings can be installed using the SEMI LOOSE LAY method by meaning loose lay with perimeter adhesion. Only for compact products such as Xtreme, Magma, etc. it is not recommended.



# 02

## ACCEPTABLE SUBSTRATES

### **Concrete slabs, cement, or anhydrite screeds**

- Sanding, and the application of a suitable primer and levelling compound are required

### **Nailed parquet flooring**

- If ventilated on the underside, a primer and fibre-reinforced levelling compound are required

### **CTBH/CTBX panels**

- If ventilated on the underside, a primer, joint treatment, or fibre-reinforced levelling compound are required

### **OSB**

- If ventilated on the underside, a primer and fibre-reinforced levelling compound or lining panels are required

### **Old PVC tiles or compact rolls, linoleum, rubber, paints, or resins**

- If more than 10% of the surface is in poor condition, the surface must be removed and renewed. If this applies to less than 10% of the surface, a partial repair may be carried out before installation if necessary.

### **Tiling**

- Vinyl floors with textile backing and a wear layer thickness of  $\geq 0.35$  mm can be installed directly on the tiled floor, if the joint is  $\leq 4$  mm wide and  $\leq 1$  mm deep, but is flush. To prevent joints being visible, we recommend applying a levelling or filling compound.

### **Asbestos vinyl tiles**

- Can be installed with Romtack ASB (Romus), RF 100 (BOSTIK), ST 100 tape (UZIN) adhesives

### **Low-temperature water underfloor heating**

- The heating must be switched off 48 hours before work begins and gradually switched back on 48 hours after installation

### **Electric radiant floor and reversible floor**

- Adhesive installation only

# 03

## INSTALLATION

**With this installation method, there are no length or width restrictions.**

Draw a reference frame in relation to the configuration of your room in order to position the rolls

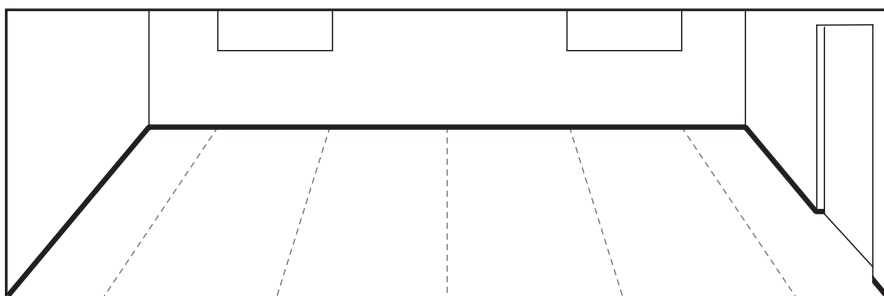

Place the adhesive strips under each joint and around the edges. For 4m and 5m wide rolls, we recommend placing an adhesive strip also in the centre.

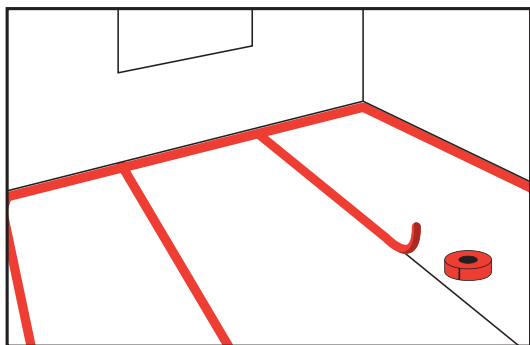

Tamp down the glued areas with a cork wedge or tamping block

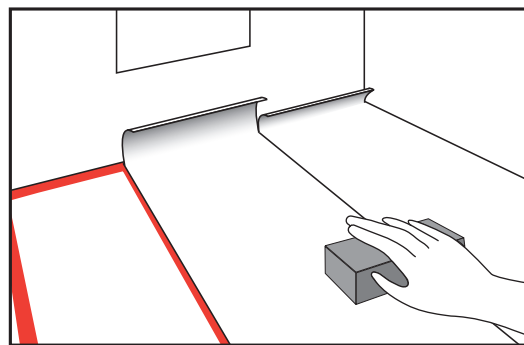

The floor covering is trimmed at the edges, leaving a space between 1 and 2 mm, and the gap is filled with MS polymer putty

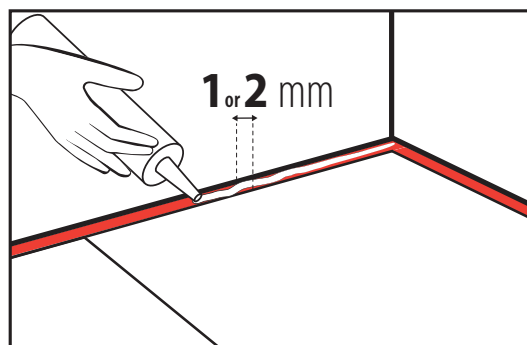
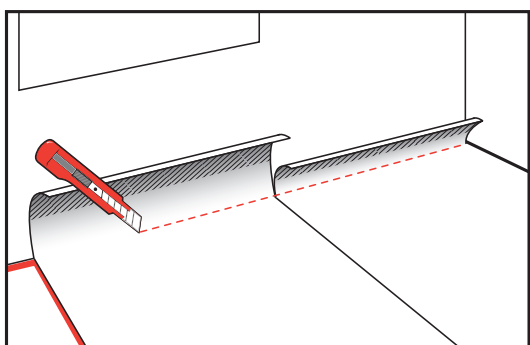

# 04

## JOINT TREATMENT

### COLD WELDING

Cold treatment of the joints is carried out after installation.

Install edge-to-edge or overlap the edges for wood finishes

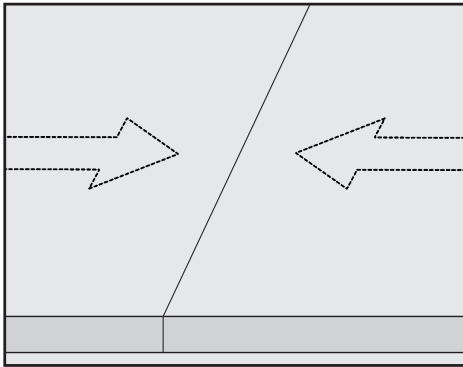

Apply masking tape to the joint

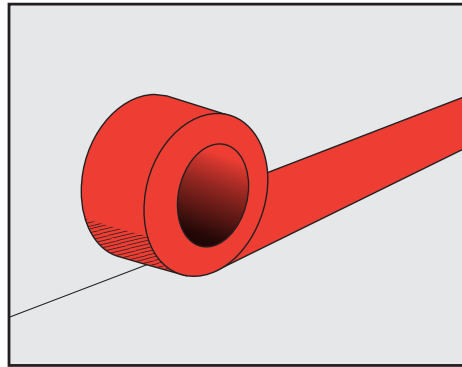

Cut the adhesive tape with a bent blade to open the joint

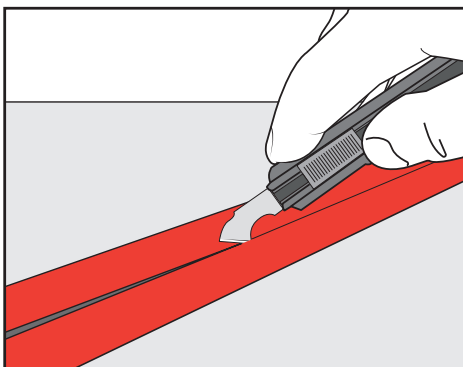

Insert the T-type nozzle into the joint and inject the product along its entire length

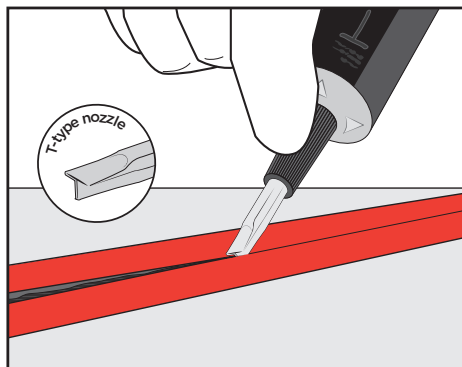

Allow to dry for about 10 minutes and remove the masking tape

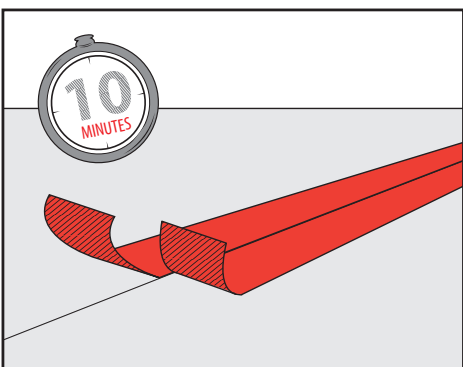

## HOT WELDING

Hot treatment of the joints is carried out after installation.

**Chamfer the joint using a manual groover, such as Linéa Ref.: 95101 from Romus / Beetle Ref.: 262 611 900 by Janser or an electric groover**

- Foam backing and textile backing: chamfer up to the foam or textile backing
- With no backing: Chamfer to 2/3 depth of the flooring

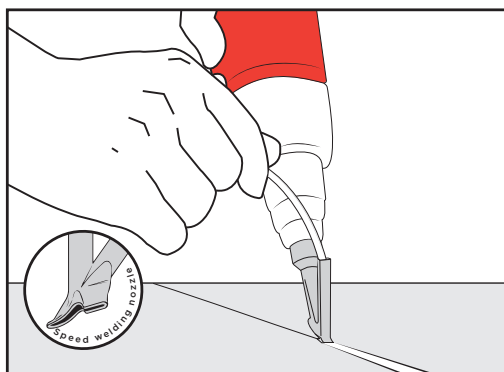
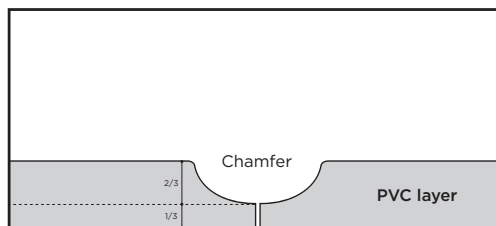
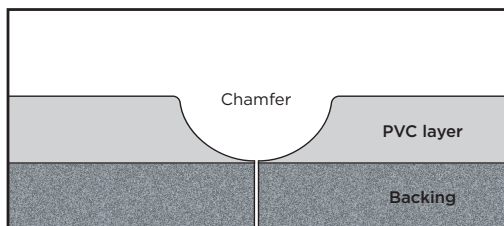

**Using a soldering iron and Rapid Ultra nozzle, solder the joint with the appropriate solder bead**

**Trim the bead in two stages using a MOZART knife**

- First using the trimming guide
- The second time without the trimming guide

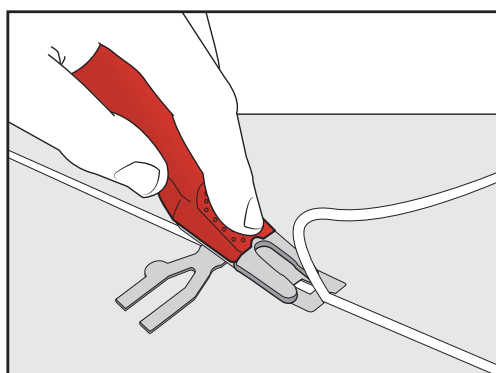
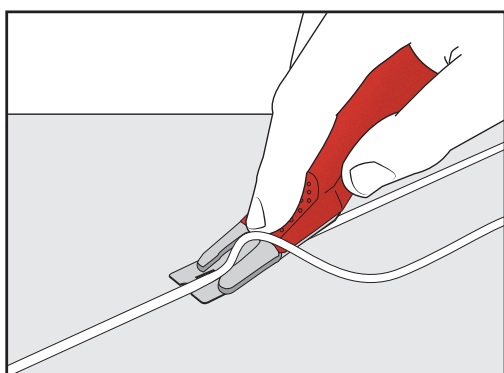



# 05

## COMMISSIONING

- Use and installing furniture after installation
- Do not use rubber leg tips
- We recommend the use of protective mats under chairs with casters
- For detailed instructions on how to care for your floor, please refer to our separate maintenance instructions. Available at [www.beauflor.com](http://www.beauflor.com).



**BEAU  
FLOR®**  
we decorate your floor

BIG Floorcoverings NV  
Rijksweg 442  
8710 Wielsbeke  
Belgium  
Tel.: +32 56 67 66 11  
Fax: +32 56 67 69 84  
[www.beauflor.com](http://www.beauflor.com)

Beaulieu  
International  
Group

